

ABM Non-Contact Level Devices

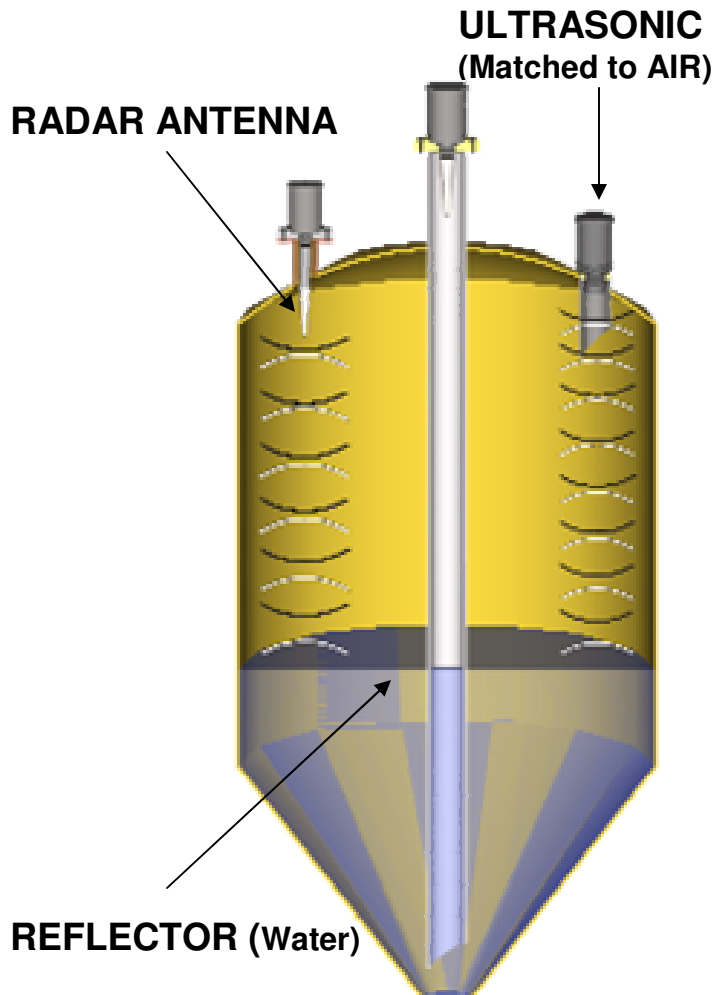

MORE AT: WWW.ABMSENSOR.COM

Propagation of Ultrasonic and Electromagnetic Waves



- Speed of Ultrasonic wave = 343m/s at 20 °C to a target
- Speed of the ultrasonic wave depends on : Temperature, Pressure and Humidity
- Any material of different density and speed of sound than air reflects ultrasonic waves
- Hard surface materials, high density (Water) give good reflections
- Soft surface materials, low density give poor reflections (Foam)
- Speed of electromagnetic waves used in radar = 300,000,000m/s
- Speed of electromagnetic waves changes due to temperature, pressure and humidity in air can be neglected
- Reflection is given by conductive materials and dielectrics of different dielectric constant than air

Principle of operation of Ultrasonic and Microwave Level Devices

1. Ultrasonic Level Device:

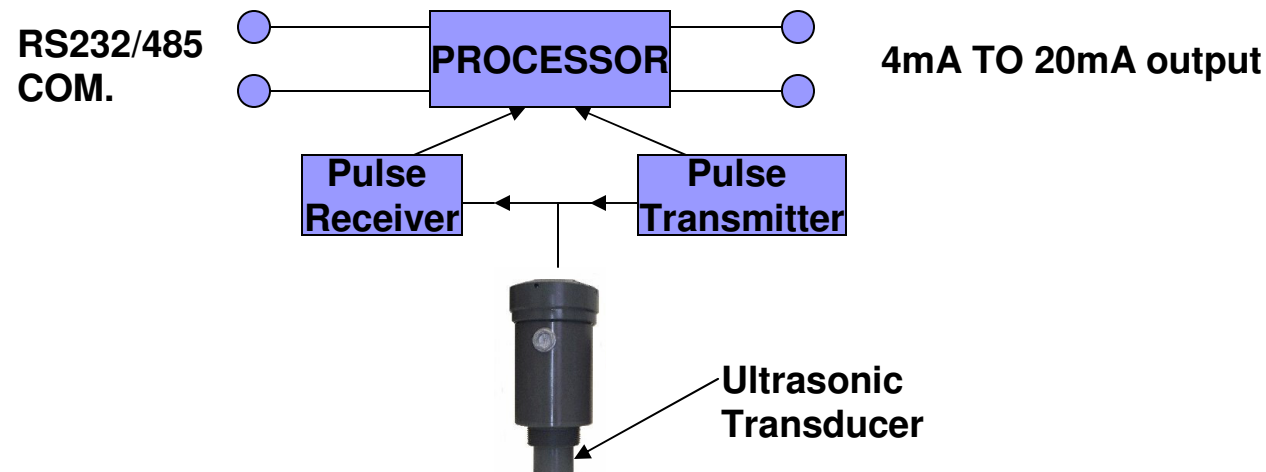

Ultrasonic transducer matched to air is stimulated by a pulse transmitter and it generates a pressure wave that propagates to a target and then reflects (Similar to a loud-speaker) . Reflected wave is received by the same transducer in the receiver mode and converted to an electrical signal (similar to a microphone). The electrical signal is amplified and processed to find the reflected echo and then calculated to find the distance to a specific target. Distances to a target are converted linearly to 4mA to 20mA current and optionally information about level measurement is sent via RS232 or RS 485 to a PC for processing such as diagnostics, programmable set-up and data logging.

2. Microwave Probes

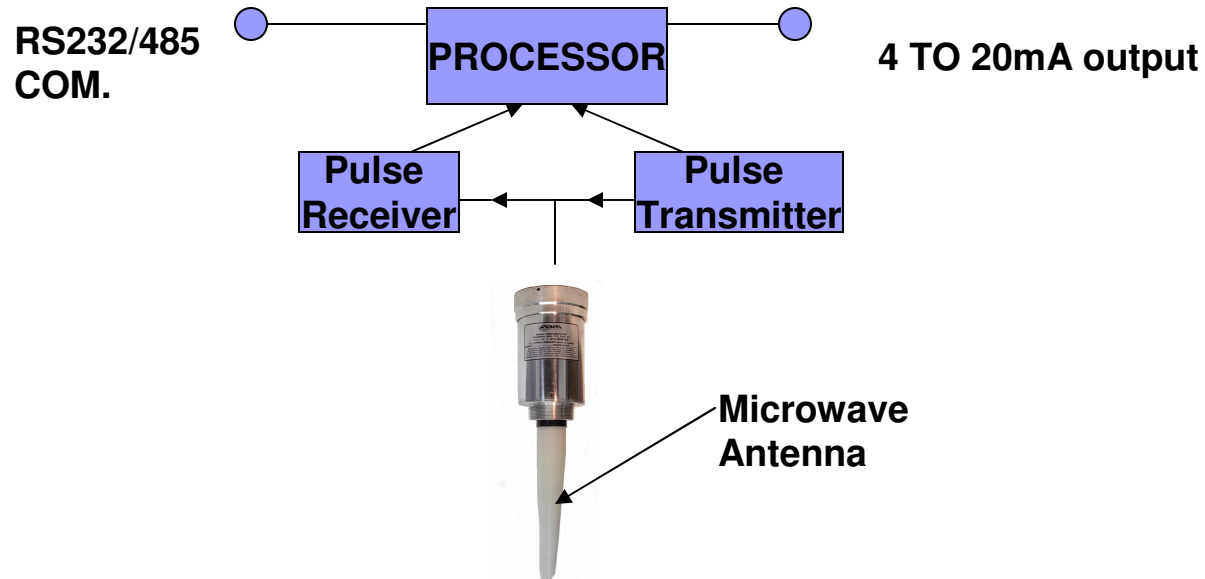

Microwave rod antenna is stimulated by an electromagnetic pulse transmitter and sends very short pulses to a target. They reflect from a target and then they are received by the same antenna. The electrical signal from the antenna is amplified and processed. Distance to an object is calculated and converted to 4mA to 20mA and also optionally, level information is sent to a PC via RS232 or RS485 for diagnostic data logging and programmable set-up.

DEVICE →



GOOD INSTALLATION

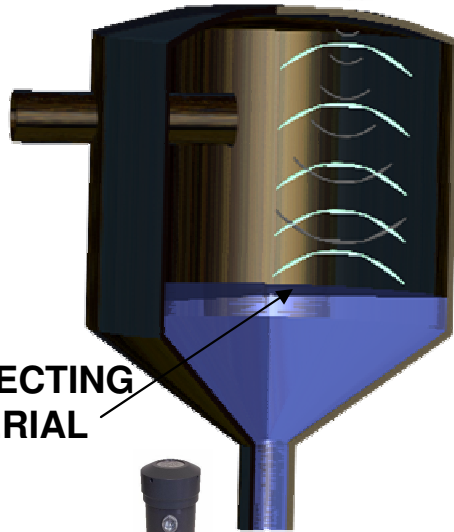

REFLECTING MATERIAL

BAD INSTALLATION

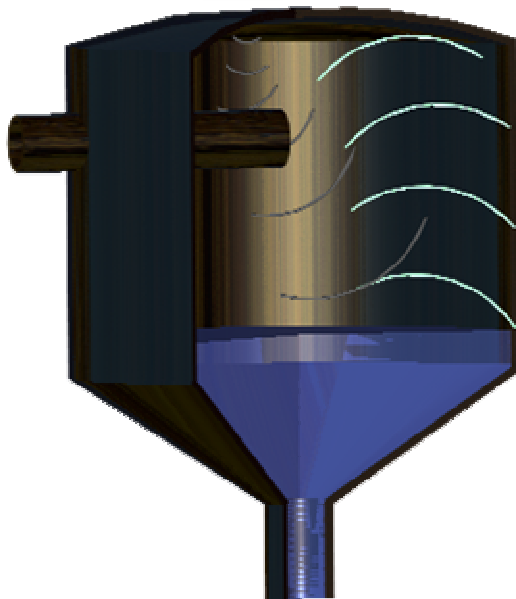

Typical Application of Ultrasonic and Microwave Devices

- For Ultrasonic Devices the tanks can be made of any material (Metal, plastic, concrete,...)
- For Microwave use metal tanks only
- Devices are mounted at the top of a tank with ABM Sensor Tech. Standard Threading or in some cases custom mounting.
- Devices have to be directed straight down to a discharge hole, even if a material is not flat (sloped). This is typical for pellets/powder applications; the devices will still receive an echo
- When installed properly the devices transmit microwave/ultrasonic waves down to a material (liquids or solids)
- During installation make sure that you do not have any large objects in front of transducer or antenna
- Reflected pulses from materials are received and processed to obtain correct distances
- Due to very narrow and uniform polar patterns (directivity) and signal processing of ultrasonic/microwave devices, small unwanted echoes from tanks walls, ladders, filling pipes, ext. can be ignored or cancelled.

Proper Mounting

When mounting a Level device either Probe or Radar in a tank that has a domed top the mounting can not be in the center. The domed top works like a satellite dish and magnifies the first receiving echo. This echo actually gets stronger than the first received echo. This creates a false echo which the software locks onto. This echo is typically twice the distance of where the material actually is.

$$\text{TAN}(\text{ALFA}) \times (\text{Height of tank}) = \text{Distance from wall}$$

Where: ALFA is a radiation beam angle

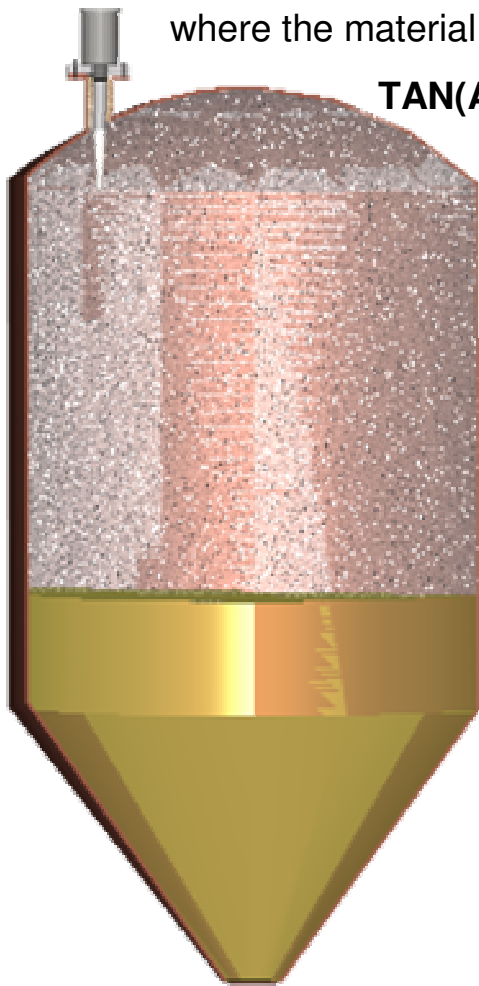

RIGHT

 = First burst and received echo

 = A BAD MAGNIFIED ECHO FROM DOMED TOP.

WRONG

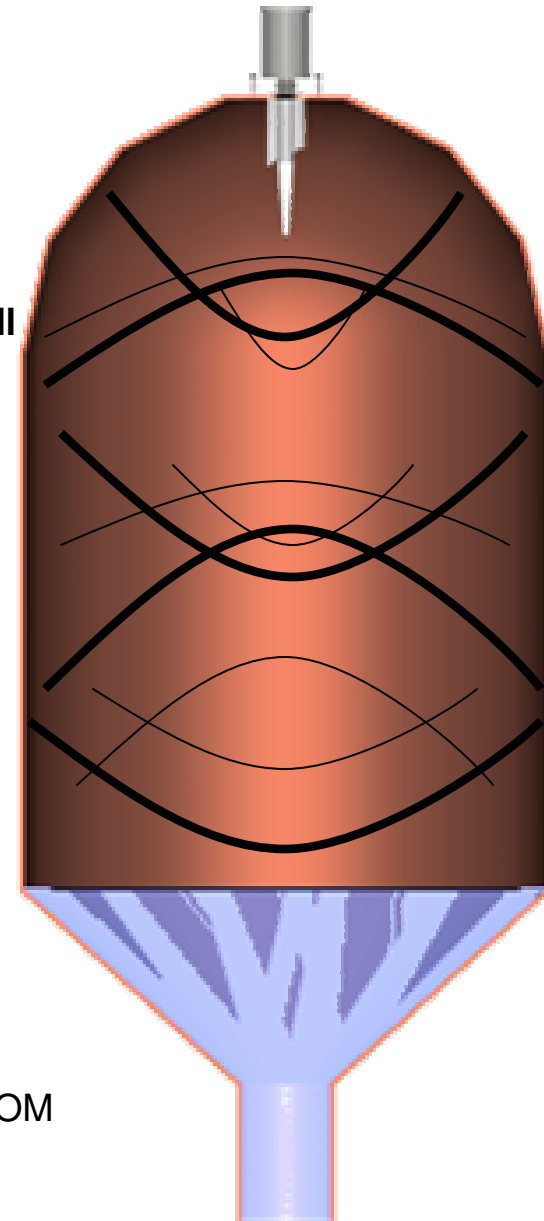

Proper Mounting

(Horizontal Tanks/Oil Tanks)

Radar must be mounted off center or in a stilling well because multiple reflections can occur. The rounded bottom of the tank can gain our radar signal and cause false readings.

**NEVER MOUNT THE SENSOR IN THE CENTER WITHOUT A STILLING WELL!!!
STILLING WELL MUST BE WITHIN 5" OF THE BOTTOM OF THE TANK WITH A 45deg. CUT.**

OFF CENTER WITH STANDPIPE



CENTER WITH STILLING WELL

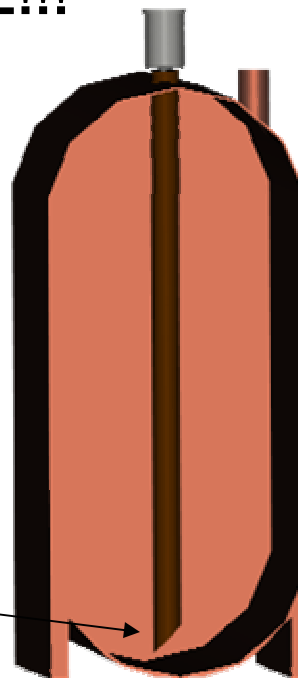

45deg. cut and within 5" of the bottom



Architecture of Ultrasonic Level Device

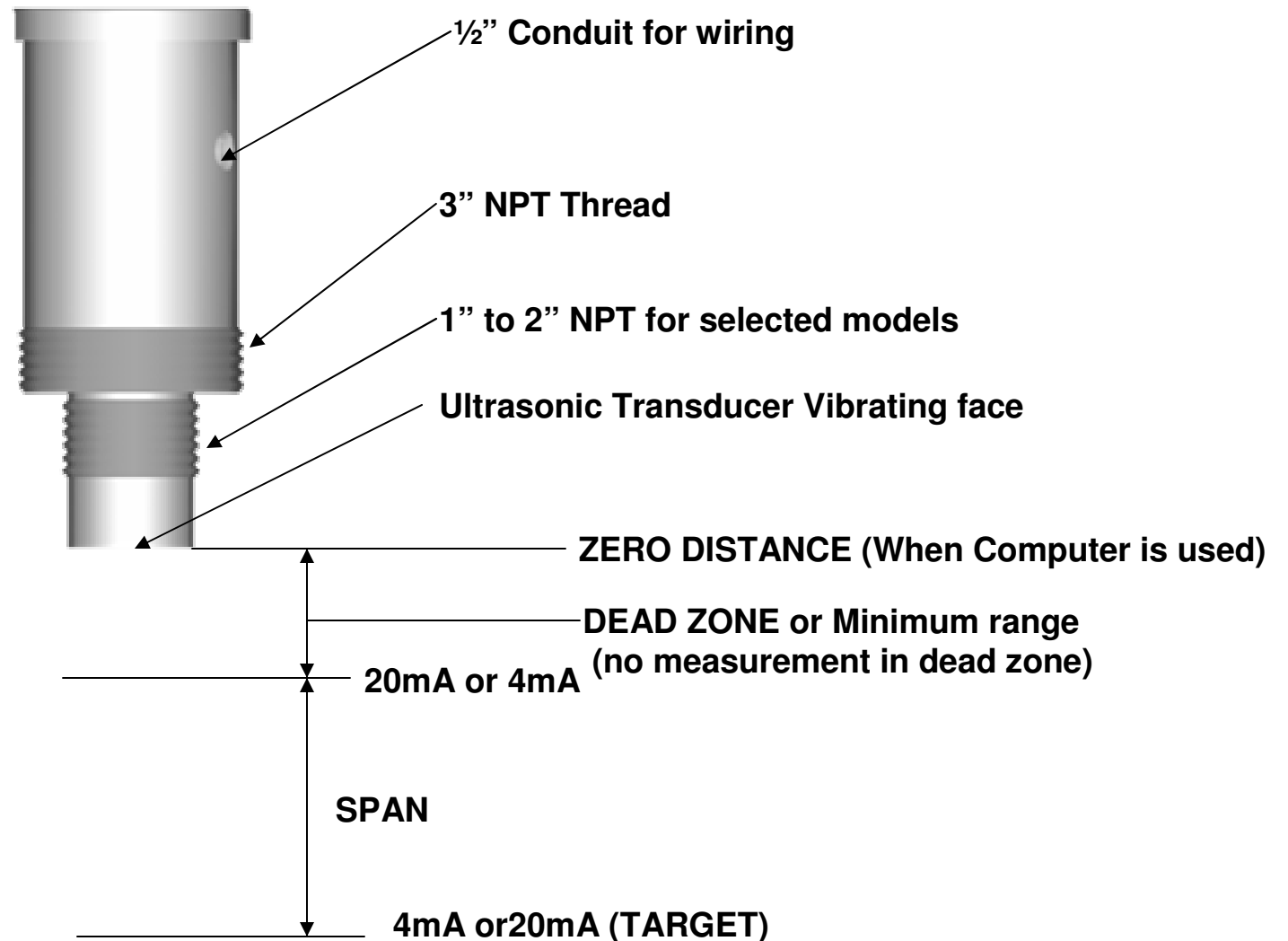

Architecture of Microwave Device

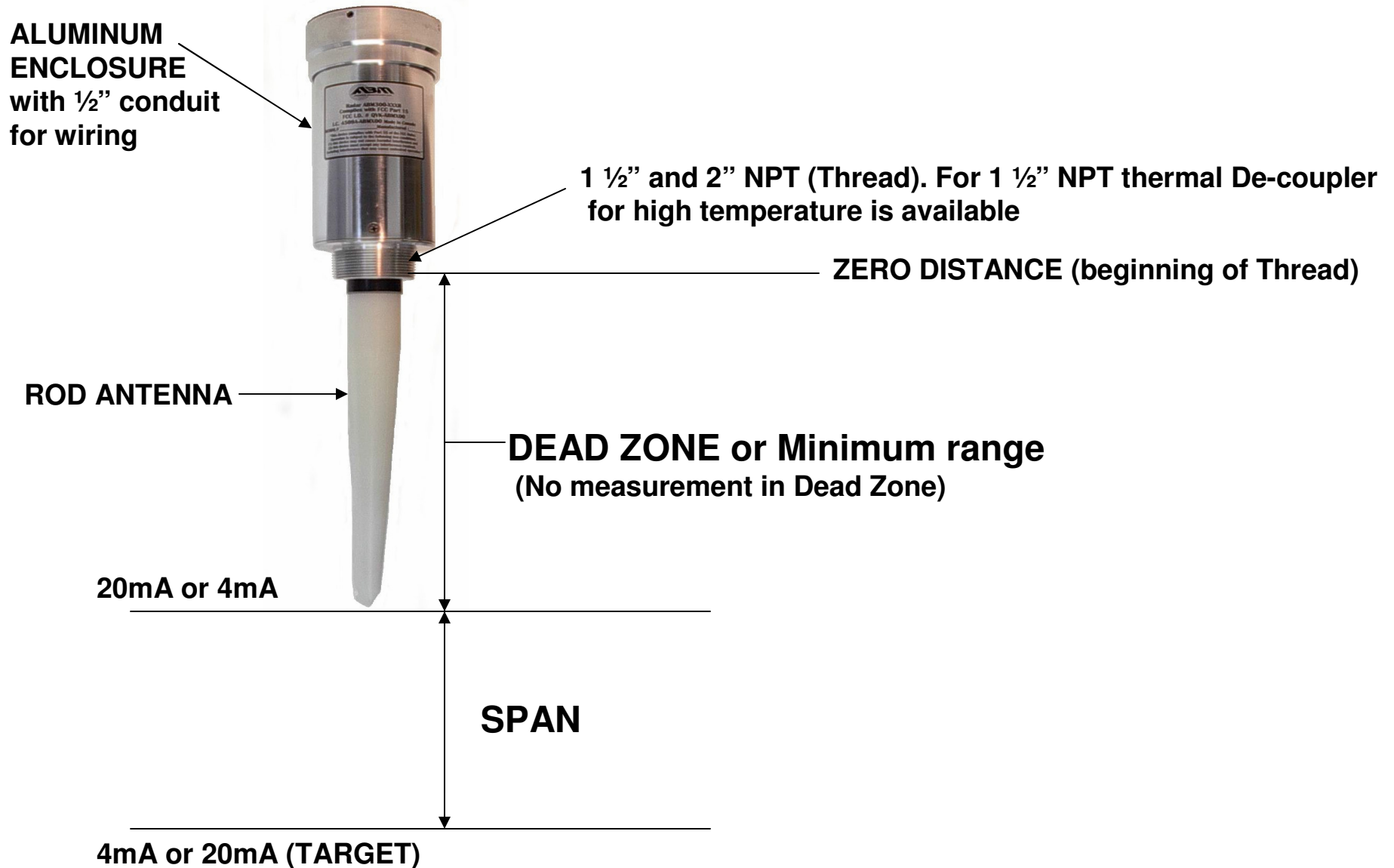

Stand Pipe and Stilling Well Mounting for Ultrasonic Devices

No termination required for pipes shorter than 6" and ID of Pipes must be greater than OD of the transducer nozzle

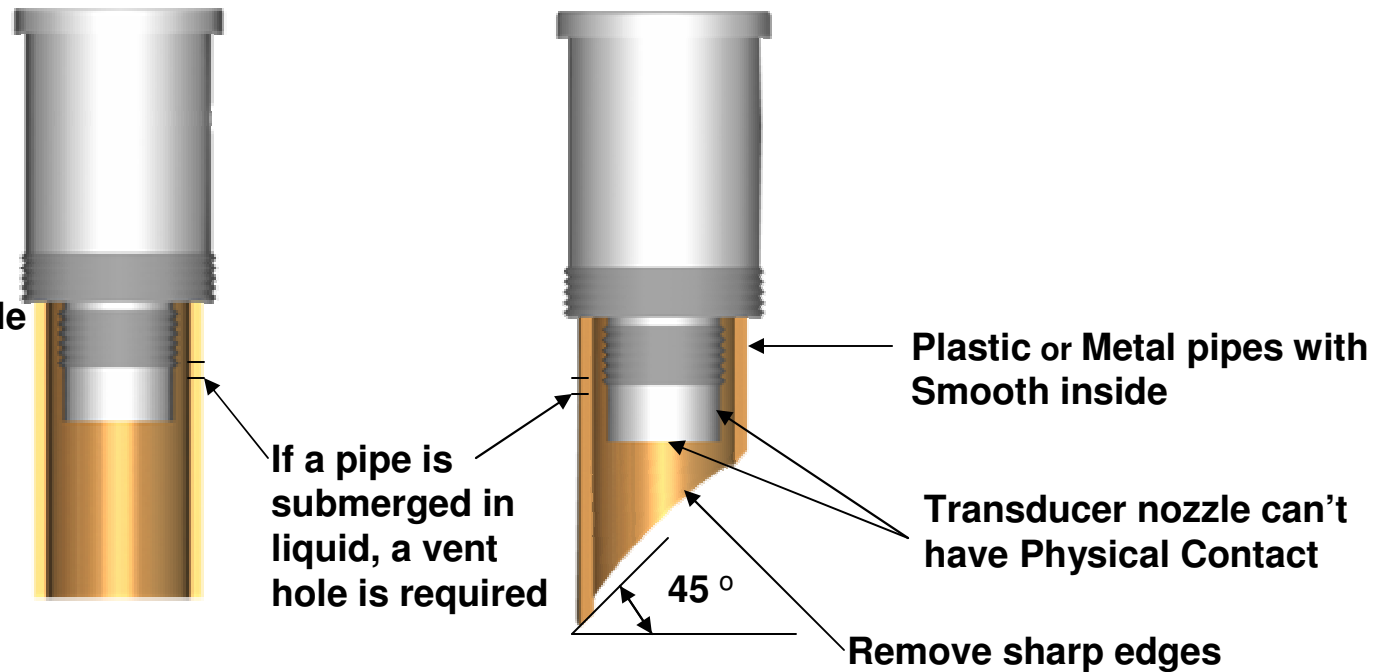

•If pipe is longer than 6" a 45° cut is required

Metal Stand Pipe and Stilling Well Mounting for Microwave Device

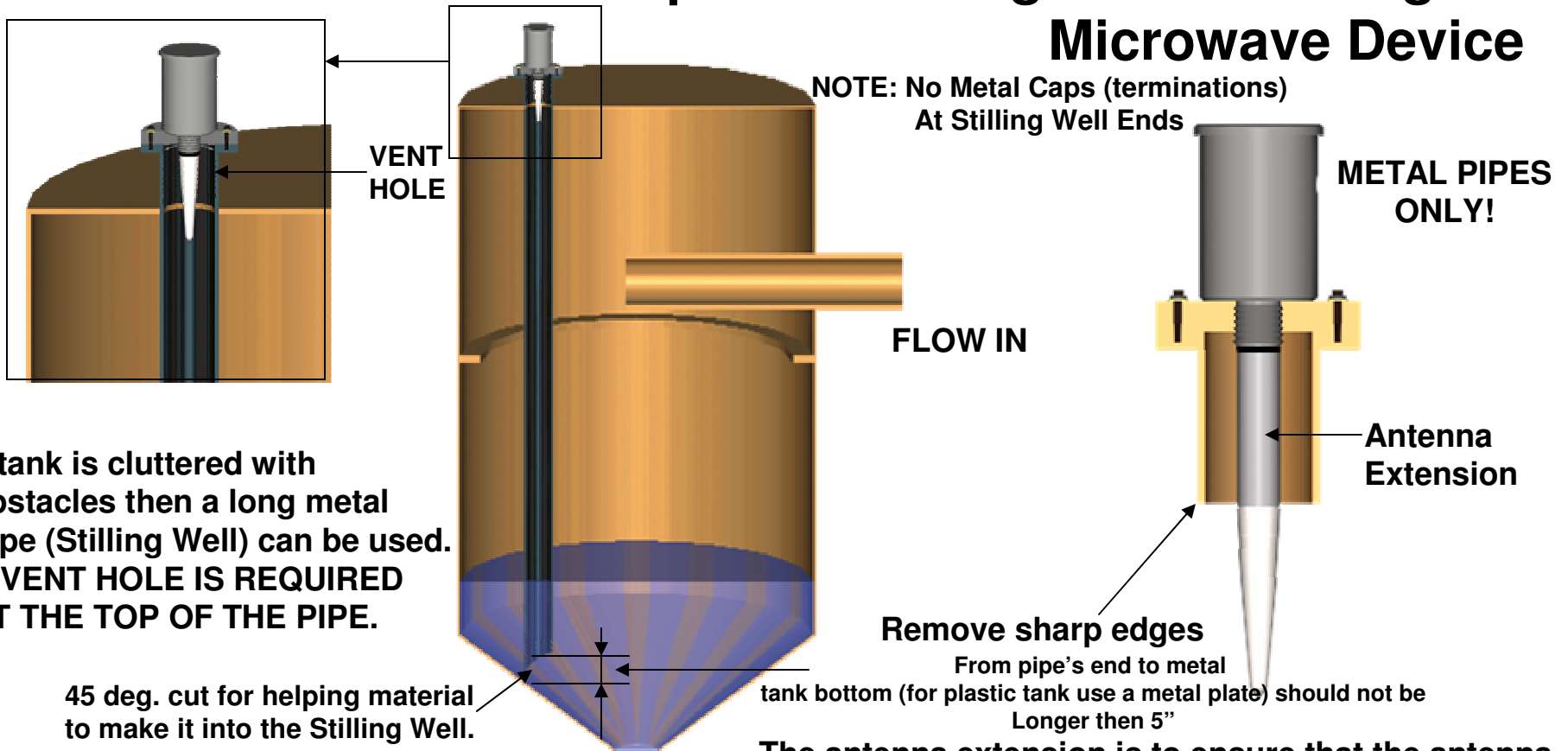

If tank is cluttered with obstacles then a long metal Pipe (Stilling Well) can be used. A VENT HOLE IS REQUIRED AT THE TOP OF THE PIPE.

45 deg. cut for helping material to make it into the Stilling Well.

For metal stand pipes use 6" or 8" Antenna Extensions that are equal or longer than small ID stand pipes

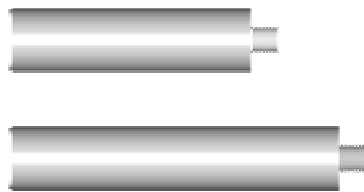

The antenna extension is to ensure that the antenna exceeds the mounting and is sitting in the tank.

MATCH EXTENSIONS WITH TEFLON ANTENNAS ONLY!

Distance to tank's wall

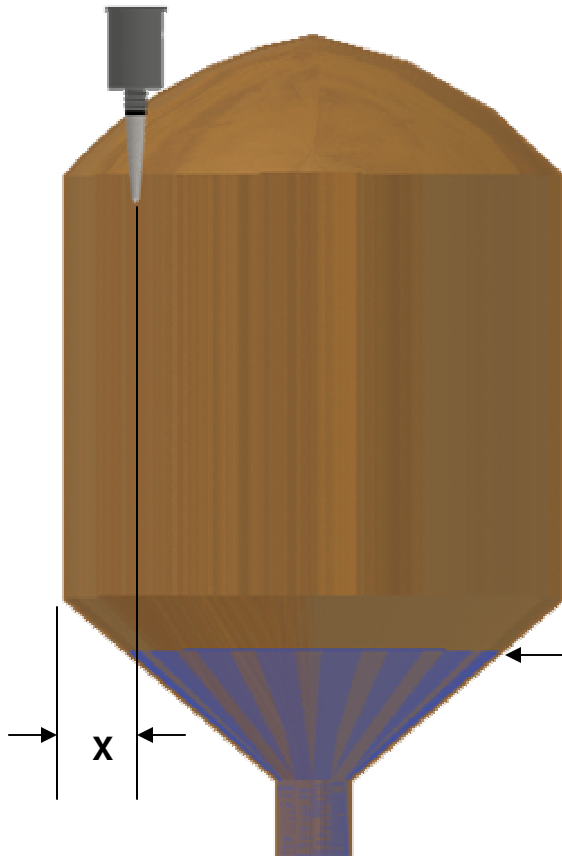

The distance from the wall after using the formula is the minimum distance allowable from the side wall based on the height of the tank.

To prevent the bouncing of the echo from the tapered bottom a **Minimum Level** can be set so there is a perpendicular reflection.

If it's not possible to have a minimum level in a tank then you can use the **Loss Of Echo** function found in the **TOOLS** menu. Either set the Loss of Echo for 2 mA or 22 mA depending on the full tank calibration setting.

Minimum Level

Minimum distance to Wall can be calculated from the equation:

$$X = \tan(\text{ALFA}/2) \times \text{height}$$

Where: ALFA is a radiation beam angle

For Ultrasonic: $\tan(12/2) = 0.1$
For Radar with rod: $\tan(20/2) = 0.18$
For Radar with Horn: $\tan(16/2) = 0.14$



Application for Ultrasonic Devices

1. Water without foam
2. Liquids without methane, CO₂ and H₂S
3. Water and solid mixtures
4. Oil without H₂S
5. Inks and water based paint containers (low fume)
6. Plastic powder, pellets, seed, grain, cement and gravel (divide max range by 2; high dust by 3)
7. Any object detection, fast moving objects
8. No vacuum
9. No rapid changes of temperature in tanks
10. Material shape detection on belt conveyers
11. Sanitary applications with CIP
12. CO₂ & methane detection
13. Any of the above with high temperature environments
14. Applications where there is up to 5 bars of pressure (no vacuums)
15. Anti-collision system
16. Pharmaceutical applications ie. small tanks
17. Top of foam detection for short distance. (Max range divided by 6)
18. Open Channel flow measurement
19. Motion detector, fast moving objects



Applications for Microwave Devices

1. Liquids with foam
2. Liquids with gases (CO₂, methane) and other fumes
3. Highly corrosive liquids such as acids and solvents
4. High temperature liquids up to 350F ie. Hot asphalt
5. In vacuumed applications
6. Rapid temperature changes
7. High acoustical noise
8. No low dielectric foam influence
9. Diesel crude oil
10. Motion detector, fast moving object
11. Metal pipes any diameter
12. Solid materials and powder with heavy dust, use 26 GHz
13. Sanitary applications
14. Outdoor level measurement of rivers, lakes and seas
15. Anti-collision systems
16. Oil-water interface monitoring and detection
17. Open Channel flow measurement for liquids with foam and outdoor applications
18. Fuel efficiency systems for ships
19. Non-intrusive operation for plastic tanks and tanks with windows



New Features of Ultrasonic and Microwave Level Devices

1. **Automatic power, pulse width and sensitivity adjustment to any tank condition (plug and play operation)**
2. **Rejections of any unwanted echoes from stand pipes, tanks walls and any other small obstructions**
3. **Self-cleaning of the ultrasonic transducers radiating faces**
4. **Ignorance to build-up on microwave antenna**
5. **Measurement of very low dielectric constant materials given by microwave device**
6. **Echo detection of materials with high angle of repose**
7. **Perfect operation in pipes, no influence**
8. **Minimal influence of mounting structures (See previous slides for detailed information).**
9. **Very narrow and uniform polar patterns of the ultrasonic transducers and antennas**
10. **Very wide operating bandwidth of the ultrasonic transducers and antennas**
11. **Adjustable Damping factor**
12. **Noise filter for ultrasonic level devices**
13. **“Window Out” for unwanted echoes**
14. **Selection of metal pipe for microwave level devices.**